

Plasti-Fab Design Manual

Floating Rafts





PlastiSpan™ Flotation Billets

Floating Rafts

Plasti-Fab PlastiSpan flotation billets can be used as the buoyancy medium to construct a variety of rafts. Several variations are shown with simple principles which can be applied to many types of floating raft variations.

General principles involve keeping the billets close to the outside edges of the raft for greater stability and leaving

space between buoyancy blocks so that waves can roll through the structure.

For more information on the design and application of floating structures, see the Plasti-Fab brochure "Buoyancy Systems: Selection, Application and Specification."

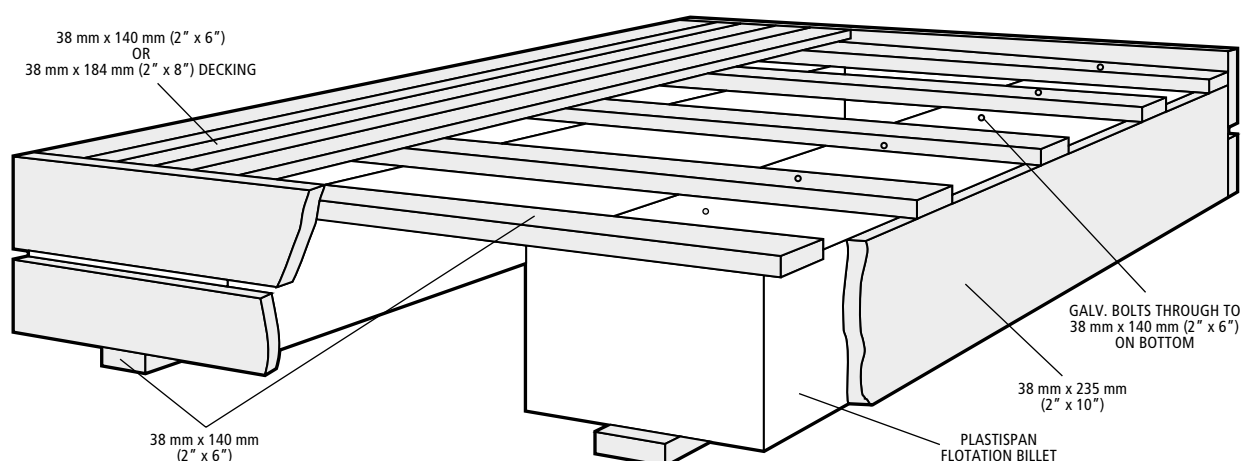

Raft

1.8 metres x 2.4 metres (6'-0" x 8'-0")

Construction

General

Use cedar or treated fir lumber. All nails, bolts and hardware should be hot dip galvanized after forming or else made from non-corroding material.

Framing

Nail outside frame together, using 38 mm x 240 mm (2" x 10") lumber for the long sides and two 38 mm x 140 mm (2" x 6") lumber of each of the short sides. On each short side nail lower piece flush with bottom of long side. Nail upper piece so it extends 75 mm (3") above edge of long side so it will be level with deck. Nail on top stringers at approximately 600 mm (24") centres.

Billets

Place billets in a frame by one of the methods shown on page 3 of the Plasti-Fab brochure "Buoyancy Systems: Selection, Application and Specification"

Decking

Nail on decking at right angles to stringers, leaving a space between the boards.

Finish

Paint the raft with a good grade of marine paint, if desired.

Diving Raft

1.8 metres x 2.4 metres (6'-0" x 8'-0")

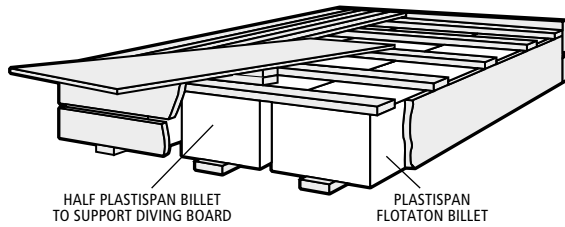

Construction

Construct as for a typical raft providing extra flotation on the side which the diving board projects. This provides support to the diving board and dampens the movement of the raft. Attach the extra billet or the half billet in the same manner as other billets.

Notes

1. Larger rafts can be built using the same construction principles. Leave space between the PlastiSpan flotation billets equal to at least 50% of billet width to allow space for waves to roll through. Locate flotation billets at the end or sides of the structure for a more stable raft.
2. Where icy conditions or floating debris are expected, be sure the skirt boards on the sides of billets extend below the water line when the dock is floating without a load to prevent damage to the billets.

Simple Raft

1.2 metres x 2.4 metres (4'-0" x 8'-0")

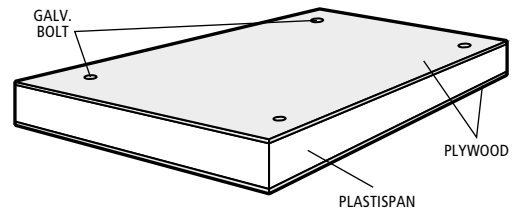

Construction

A simple raft can be made from two 1.2 metres x 2.4 metres (4'-0" x 8'-0") sheets of 10 mm (3/8") plywood or particle board with a 100 mm or 150 mm (4" or 6") thick PlastiSpan board sandwiched between.

Bolt the raft components together with 150 mm or 200 mm (6" or 8") galvanized bolts. If one of the bolts is increased in length, an extra nut and an eye provides attachment for an anchor.

A raft using 100 mm (4") thick PlastiSpan insulation board will support up to 225 kg (500 lbs). Use 150 mm (6") thick PlastiSpan insulation board for support up to 340 kg (750 lbs).